



PSA-3002

Compact PowerSync® Analyzer

IEEE 802.3at Power over Ethernet

Product Overview

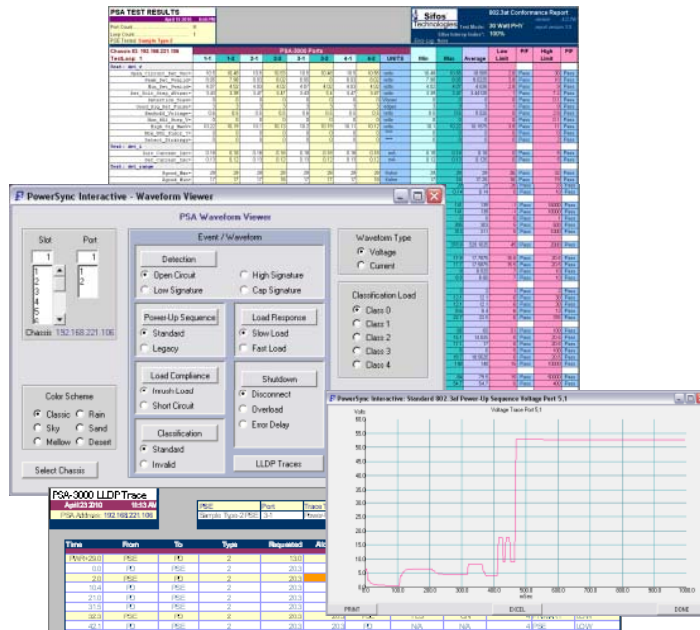

Key Features

- Industry Leading IEEE 802.3 PoE PSE Conformance Tests
- Replaces All General Purpose Test Equipment & Fixtures
- Small, Light Weight, Transportable
- Static PSE Loading > 42 Watts Per Test Port (2 Test Ports)
- One-Button Waveform Production and Analysis
- Flexible Powered Device LLDP Emulation and LLDP Analysis
- Flexible and Accurate Measurements of Voltage, Current, Noise
- Noise Immune Triggering, Transients, and Time Interval Measurements
- Enables PSE Packet Transmission Testing with PoE Loads
- Flexible Script Automation and Graphical User Interface for Microsoft Windows and Linux PC's.
- Backward Compatible to Sifos PSA-100 Analyzers

real Power from Sifos

**802.3at End-Span
PSE, Mid-Span
PSE, PSE
Controller, and
Integrated Modular
Connector
Development....**

**Versatile IEEE
802.3at
Compliance and
DV Test....**

**Engineering and
Manufacturing
Script
Development
Tool....**

**Portable PoE
Service
Analyzer....**

Overview

Power-over-Ethernet (PoE) challenges design and test engineers to evaluate multi-channel, “intelligent” DC power sources that are activated and deactivated through signaling protocols operating over several power delivery and polarity configurations. The application and management of DC power over multiple local area network connections must be completely transparent and non-disruptive to the traditional data transmission functions of those network connections.

One Box Solution

Sifos Technologies provides a **one-box solution** to facilitate complete testing and analysis of Power Sourcing Equipment (PSE) behaviors and overall compliance to the **IEEE 802.3at** specification. Each test port inside a PowerSync Analyzer is an autonomous and fully isolated instrument offering a rich set of stimulus and measurement resources. Test ports are configured and controlled via a high level automation interface, **PowerShell PSA**, and may also be accessed and managed from an intuitive graphical user interface, **PSA Interactive**.

Automated PSE Conformance Testing

The PSA-3002 may be optioned via a license key to run the world’s most advanced **PSE Conformance Test Suite**. This fully automated application applies the PowerSync Analyzer’s diverse resources to assess over 60 IEEE 802.3at specification parameters presented in easily readable spreadsheet reports with port statistics and clearly notated pass/fail limit analysis.

LLDP Emulation

The IEEE 802.3at specification describes a new generation of PSE’s and Powered Devices (PD’s) that communicate highly resolved power needs and power allocations using Ethernet layer 2 (LLDP) link protocols. The PSA-3002 may be optioned via a license key to flexibly emulate PD’s and fully analyze the new power negotiation protocols between PSE’s and PD’s.

Start Small and Grow

The PSA-3002 is well suited to early device qualification and design verification applications as well as to field application and support activities. Test plans and software developed with the PSA-3002 are readily extendable into PSA-3000 (24-port) and PSA-3048 (48-port) test platforms.

Second Generation PoE Solution from Sifos

The PSA-3000 family is a second generation family of products from Sifos specifically developed to address the IEEE 802.3at specification. First generation PSA-1200 products established Sifos as the industry standard world-wide for comprehensive PSE testing and analysis. The PSA-3000 family fully supports test procedures and automation developed for PSA-1200 analyzers while offering increased static and transient load stimuli, higher set point and measurement accuracies, higher resolutions, reliable noise-immune triggering, robust LLDP emulation, active load foldback suppression, and many other advantages relative to the first generation PowerSync Analyzers from Sifos Technologies.

real Power from Sifos

PowerSync Analyzer Test Equipment Setup: PSE Testing

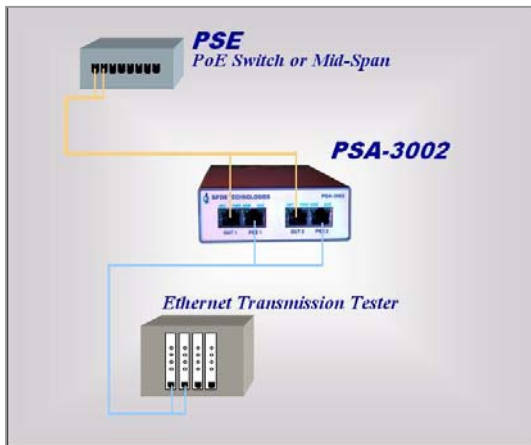

PowerSync Analyzer Test Equipment Setup: PoE Service Analysis

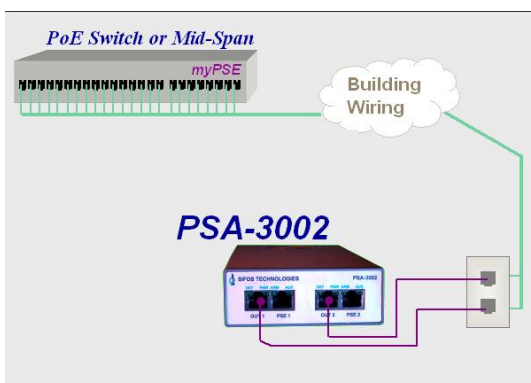

Per-Port PSE Test Resources

Flexible PD Detection & Class Emulation

Flexible Loads and Load Transients

Event or Noise-Immune Edge Triggering of Load Transients & Measurements

Average, Peak (Min/Max), and Trace Measurements of Port Voltage and Load Current with Flexible Sampling Intervals

Standard One-Button Waveform Library for Rapid PSE Analysis and Conformance Troubleshooting

Flexibly Triggered, Noise-Immune Time Intervals / Slew Rates

O-Scope Graphical Waveforms

LAN Termination, LLDP Protocol Emulation and Tracing

Concurrent Packet Transmission and PoE Load Testing

External Trigger Input/Output

PSE Conformance Suite

High Coverage, Fully Automated IEEE 802.3 PSE Compliance Testing and Analysis

Over 20 PSE Tests Producing Over 65 Parameters Per Port

Automated Test and Port Sequencing with Comprehensive, Colorful Spreadsheet Reporting

Automatically Adapts to PSE Device Technologies

Updated with Sifos Tracking Service Agreements

New IEEE 802.3at PSE Conformance Test Suite (including LLDP Emulation options)

LLDP & LAN Test Support

Flexible, Per-Port, Programmable PD LLDP Emulation for PoE with Payload, Timing, & Synchronization Control

Fully Automated LLDP Protocol Traces and Analysis

Test Port "Through" Channel for LAN Transmission Testing with or without PoE Port Power

Negligible Through-Channel LAN Impairment

PoE Service Analyzer*

Comprehensive Evaluation of PoE Service at a PD Interface

PoE Service Interoperability Analysis

In-Band Control of PoE Service-Under-Test

Colorful Spreadsheet Reporting

Powerful Software

PSA Interactive GUI for Control of all Test & Diagnostic Resources

Automated Test Menus for PSE Conformance and PoE Service Test Suites

Comprehensive, User-Friendly PowerShell Script Development and Execution Environment Built on Tcl/Tk

* Restricted to Type-1 (PD Classes 0 – 3) Emulations as of PSA 3.5 Software Release, April 2010. Extensions to PD Class 4 and LLDP Emulation planned in future releases.

PSA Interactive Graphical User Interface

The Sifos PSA Interactive Graphical User Interface (GUI) is a flexible and powerful tool designed to allow users to quickly configure and perform both standard and user-defined measurements on IEEE 802.3 compliant power sourcing equipment (PSE). PSA Interactive provides an intuitive view of the full range of testing resources available within the PSA-3002 PowerSync Analyzer. Users can quickly harness the flexibility and power of these resources to perform design verification and diagnostic measurements or to prototype sequences that will eventually be automated in PowerShell PSA scripts.

PSA Interactive organizes PSA-3002 resources and testing features into nine distinct subsystems:

- Port Detection Configuration
- Trigger Configuration
- Load and Load Transient Configuration and Activation
- DC Meters (Average, Max Peak, Min Peak, and Trace Voltage and Current meters)
- AC Peak Voltage Meter
- Time Interval / Slew Rate Meter
- PSE Conformance Tests
- PSE Conformance Test Sequencer
- Standard Waveform and LLDP Viewer

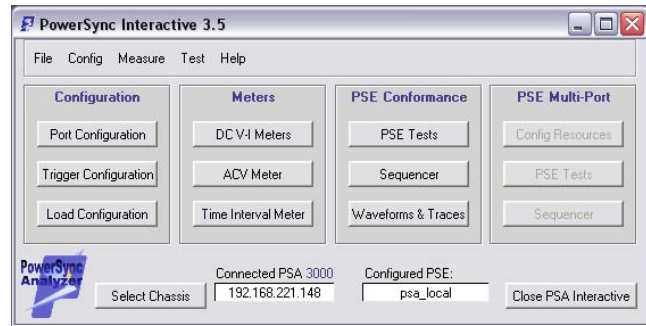

PSA Interactive Main Menu

PSA Interactive enables rapid single or two-port configurations and one-button testing and analysis through intuitive subsystem dialogs that flexibly address test ports and PSA chassis'.

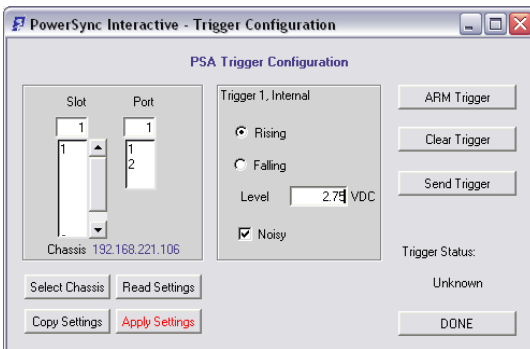

Waveform Trigger Configuration Menu

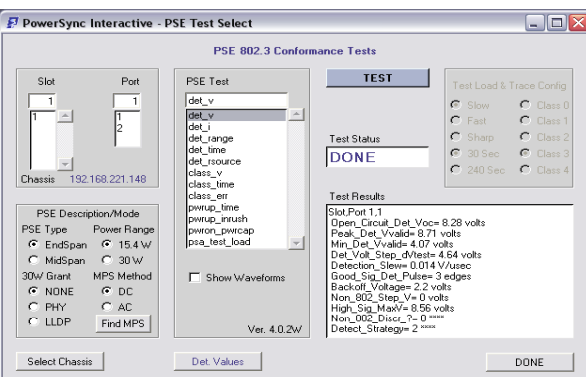
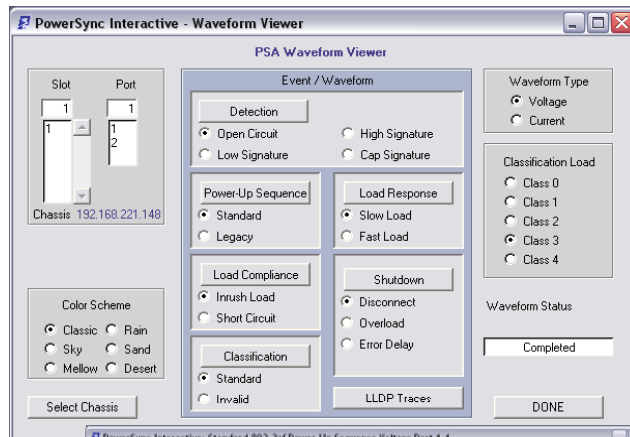

PSE Conformance Selected Test Menu

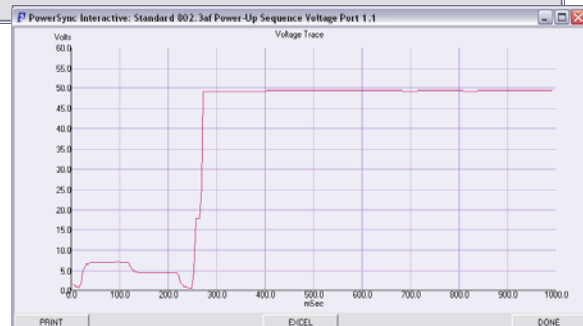

One-Button Waveform Capture & Analysis

PowerShell PSA Tcl/Tk Interface

The PowerShell PSA Scripting Environment provides a high level, live-keyboard means to control and program automated test sequences for the PSA-3002 PowerSync Analyzer. PowerShell enables fully automated testing suites that span multiple ports, blades, and frames. Built upon the popular Tool Command Language (Tcl), it offers an extensive and extensible programming language.

PowerShell PSA provides a complete API for the PSA-3002 including high level commands that execute and sequence standard **802.3 PSE Conformance Tests** and **LLDP Protocol Traces**. PowerShell commands access all of the resources of the PSA-3002 and enable the rapid development of highly customized test scripts. PowerShell fully supports off-line script development and debug through its robust built-in emulation mode.

PowerShell PSA libraries can be integrated into broader Tcl environments that interlace traditional network transmission tests with Power-over-Ethernet tests. This enables seamless integration of custom or standard PSE tests with existing Tcl-based test suites.

Other features offered by the PowerShell Tcl environment include:

- Interpretive command execution (no compilation, simple debug)
- Simple, intuitive PowerSync Analyzer commands (API)
- Integrated command “help” tools
- Full access to PSA triggering and signal synchronizing features
- Fast test execution speeds
- Script-configured test report files
- Use in tandem with PSA Interactive GUI
- AnyEdit Smart Editor for PowerShell PSA
- Traditional Tcl Console or Command-Knowledgeable Wish Console with PSA waveform viewer capability

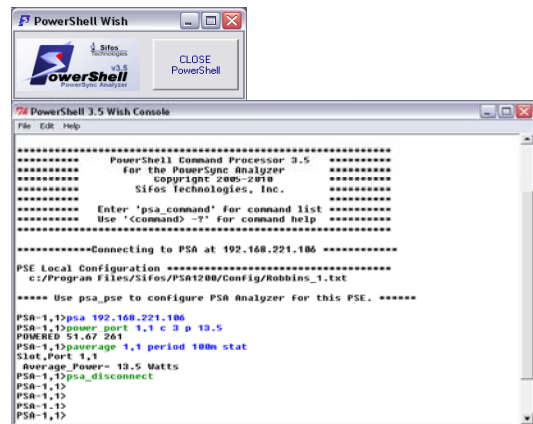

PowerShell Wish Console

IEEE 802.3 PSE Conformance Test Suite

The IEEE 802.3 PSE Conformance Test Suite is a library of **fully automated, flexibly sequenced, and self-adapting** tests that provide a high degree of specification compliance testing on PSE ports without the need for any external instrumentation. These tests are accessible to both PSA Interactive (GUI) and to PowerShell.

The **PSE Conformance Test Suite** consists of the following modules for testing **802.3at compliant Type-1 and Type-2** PSE's:

- | | |
|--|---|
| ➤ Detection Voltages | ➤ PSE Power Capacity |
| ➤ Detection Current Compliance | ➤ Extreme Overload Tolerances |
| ➤ Detection Acceptance Range (R and C) | ➤ Transient Overload Tolerances |
| ➤ Detection Timing | ➤ DC MPS Validity |
| ➤ PSE Source Resistance | ➤ DC MPS Shutdown |
| ➤ Classification Voltage | ➤ AC MPS Shutdown |
| ➤ Classification Timing | ➤ AC MPS Signal Characteristics |
| ➤ Classification Errors | ➤ Overload Shutdowns |
| ➤ LLDP Negotiation Protocol | ➤ Turn-Off Time |
| ➤ Power-Up Turn-On and Rise Time | ➤ Turn-Off Voltage |
| ➤ Power-Up Inrush Compliance | ➤ PSE Output Capacitance & Shunt Resistance |
| ➤ PSE Voltage, Ripple, & Noise | |

Each test captures and reports one or more parameters that are directly related to the IEEE 802.3 specification. Under sequencer control, multiple PSE tests can automatically sequence across multiple PSE ports in accordance with user selections.

The 802.3 PSE Conformance Test Suite includes several report generation options including automatic Microsoft Excel spreadsheet that reports test results, test statistics, test limits, and pass/fail results on one or more cycles of testing. A partial sample of a PSE Conformance Test Suite test report is shown below:

PSA TEST RESULTS		April 15 2010 9:50 PM		Sifos Technologies		802.3at Conformance Report		version 4.0.2W		
Port Count..... 2		Loop Count..... 1		Test Mode: 30 Watt LLDP		Sifos Interop Index*: 88%		report version 3.5		
PSE Tested: Sample 8-Port Type-2 LLDP PSE		Chassis ID: 192.168.221.103		PSA-3000 Ports		Error Log: None				
TestLoop: 1	1-1	1-2	UNITS	Min	Max	Average	Low Limit	P/F	High Limit	P/F
Test: det_v										
Open_Circuit_Det_Voc=	13.9	13.98	volts	13.9	13.98	13.94	2.8	Pass	30	Pass
Peak_Det_Vvalid=	7.06	6.97	volts	6.97	7.06	7.015	3.8	Pass	10	Pass
Min_Det_Vvalid=	4.99	4.96	volts	4.96	4.99	4.975	2.8	Pass	9	Pass
Det_Volt_Step_dVtest=	1.35	1.31	volts	1.31	1.35	1.33	1	Pass	7.2	Pass
Detection_Slow=	0	0	V/usec	0	0	0	0	Pass	0.1	Pass
Good_Sig_Det_Pulse=	3	3	edges	3	3	3	1	Pass	9	Pass
Backoff_Voltage=	0.4	0.3	volts	0.3	0.4	0.35	0	Pass	9	Pass
Non_802_Step_V=	0	0	volts	0	0	0	0	Pass	0.1	Pass
High_Sig_MaxV=	10.92	10.84	volts	10.84	10.92	10.88	3.8	Pass	11	Pass
Non_802_Discr_?=	0	0	****	0	0	0	0	Pass	0	Pass
Detect_Strategy=	0	0	****	0	0	0	0	Pass	2	Pass
Test: det_i										
Init_Current_Isc=	0.22	0.21	mA	0.21	0.22	0.215	0	Pass	5	Pass
Det_Current_Isc=	0.17	0.17	mA	0.17	0.17	0.17	0	Pass	5	Pass
Test: det_range										
Rgood_Max=	31	30	Kohm	30	31	30.5	26	Pass	32	Pass
Rgood_Min=	17	17	Kohm	17	17	17	16	Pass	19	Pass
Rmid_det=	31	30	Kohm	30	31	30.5	26	Pass	33	Pass
Cgood_Max=	0.14	0.14	uF	0.14	0.14	0.14	0	Pass	10	Pass
Test: det_time										
Backoff_Time_Tdbo=	55	55	msec	55	55	55	-1	Pass	16000	Pass
Eff_Backoff_Tdbo_eff=	55	55	msec	55	55	55	-1	Pass	16000	Pass
Backoff_Type=	0	0	****	0	0	0	0	Pass	1	Pass
Detection_Time_Tdet=	289	293	msec	289	293	291	5	Pass	500	Pass
Total_Det_Time=	297	301	msec	297	301	299	5	Pass	1000	Pass
Test: det_resource										
Output_Impedance_Zout=	152.9	182.9	KOhm	152.9	182.9	167.9	45	Pass	2000	Pass
Test: class_v										
Class_Voltage_Vclass=	17.3	17.2	volts	17.2	17.3	17.25	15.5	Pass	20.5	Pass
Vclass_Min=	17.2	17.1	volts	17.1	17.2	17.15	15.5	Pass	20.5	Pass
Test: class_time										
Event_Count=	1	1	****	1	1	1	1	Pass	2	Pass
Class_Time_Tpdc=	37.1	37.1	msec	37.1	37.1	37.1	6	Pass	75	Pass
Test: class_err										
Class_lim=	75	75	mA	75	75	75	51	Pass	100	Pass
Vport_CL_lim=	52.9	52.9	V	52.9	52.9	52.9	0	Pass	20.5	Fail
Vport_CL_err_l=	17.1	17	V	17	17.1	17.05	0	Pass	20.5	Pass
Test: class_lldp										
PSE_Source_Priority=	0	0	*	0	0	0	0	Pass	0	Pass
PSE_MDI_Pwr_Sup=	9	9	*	9	9	9	0	Pass	0	Fail
PSE_LLDP_Time_2=	17.3	16.6	sec	16.6	17.3	16.95	0	Pass	10	Fail
PSE_LLDP_Type_2=	2	2	*	2	2	2	2	Pass	2	Pass
PSE_Echo_Time_2=	0.4	0.4	sec	0.4	0.4	0.4	0	Pass	10	Pass
PSE_Alloc_Pwr_2=	20.3	20.3	Watts	20.3	20.3	20.3	20.3	Pass	25.5	Pass
PSE_Alloc_Time_2=	0.4	0.4	sec	0.4	0.4	0.4	0	Pass	30	Pass
PD_Power_Adjust_2=	25.5	25.5	Watts	25.5	25.5	25.5	25.5	Pass	25.5	Pass
PSE_Adjust_Time_2=	0.4	0.4	sec	0.4	0.4	0.4	0	Pass	10	Pass
Test: pwrup_time										
Pwr-On_Rise_Time_Trise=	62	64	usec	62	64	63	15	Pass	50000	Pass
Power-On_Time_Tpon=	386.7	390.6	msec	386.7	390.6	388.65	0	Pass	400	Pass
Test: pwrup_inrush										
Init_Inrush=	441.5	442.13	mA	441.5	442.13	441.815	400	Pass	512	Pass
Max_Inrush_c4=	438.88	441	mA	438.88	441	439.94	400	Pass	450	Pass
Min_Inrush=	433.75	434.5	mA	433.75	434.5	434.125	400	Pass	450	Pass
Tinrush=	54.5	55.3	msec	54.5	55.3	54.9	50	Pass	75	Pass
Inrush_45m=	52.9	52.9	Volts	52.9	52.9	52.9	50	Pass	57	Pass
Inrush_Voltage=	35.5	35.6	Volts	35.5	35.6	35.55	30	Pass	57	Pass
Max_Init_Inrush=	559.5	560.5	mA	559.5	560.5	560	0	Pass	2000	Pass
Inrush_Strategy=	0	0	****	0	0	0	0	Pass	0	Pass
Test: pwrcon_pwracap										
Pcon_c4=	27	27	watts	27	27	27	30	Fail	38.9	Pass
Icon_c4=	517	516	mA	516	517	516.5	526.3	Fail	683	Pass
Type-2_Enable=	0	0	****	0	0	0	0	Pass	0	Pass

PoE LLDP Emulation and Analysis

The PSA-3000 includes a subsystem designed to flexibly emulate LLDP capable PD's on a per test port basis. Fully automated applications allow in depth capture and analysis of protocol between the PSE and the PD.

See [Sifos Technologies, LLDP Emulation and Analysis Overview](#) for further information on this topic. **POE**

Service Analyzer Application

The PoE Service Analyzer is a special automated test and reporting application to enable comprehensive parametric and interoperability analysis at any PD connection point in a PoE enabled wiring plant.

See [Sifos Technologies, PoE Service Analyzer Product Overview](#) for further information regarding the PoE Service Analyzer.

Technical Data: PSA-3002

LAN Interface Specifications			
Operating Mode	Signal Path	Parameter	Specification
Data Through Mode	PSE-# to OUT-#	Connections	RJ45
		Data Rates and Signaling	10/100/1000BaseT
		Latency	0 (Passively Coupled)
		Impedance	100Ω, Balanced
		Pair-Pair Isolation	≥ 36dB @ 100MHz
		Insertion Loss	≤ 2dB, 0.1MHz to 100 MHz
		Insertion Loss Variation	≤ 0.75dB, 0.1MHz to 100 MHz
Data Connect (LLDP Emulation) Mode	PSE-# to Blade Transceiver	Connection	RJ45
		Data Rate and Signaling	10BaseT
		Orientation	MDI End Point
		Protocol	802.1ab, 802.3bc, 802.3at
		Impedance	100Ω, Balanced
		Return Loss	≤ -20dB, 1MHz to 100MHz
		Return Loss (OUT pairs terminated into 100Ω)	≤ -24dB, 1MHz to 100MHz

PoE Port Connections			
Operating Mode	Dependency	Parameter	Selections
2-Pair Power	Port 1 and Port 2 operate independently	Powered Pair	ALT-A or ALT-B
		Polarity	MDI or MDI-X
4-Pair Power	Connect to Port 2 (Port 1 bypassed)	Powered Pair	ALT-A and ALT-B
		Polarity	MDI or MDI-X for each pair

Detection and AC MPS Specifications			
Description	Conditions	Parameter	Specification
Detection Resistance	Vport = 2.5VDC - 12VDC, Port Connected, Transition Current Load = 0	Range	9 KΩ to 39 KΩ
		Resolution	1 KΩ
		Accuracy $\Delta V / \Delta I$ at 1 Volt Spacings	≤ 24KΩ, ± 250Ω > 24KΩ, ± 400Ω
Detection Capacitance	Vport = 2.5VDC - 12VDC, Port Connected, Transition Current Load = 0	Range	0.14, 5, 7, 11μF
		Accuracy	15%
Detection Signature Cut-Off Threshold	Port Connected	Vport	12V ± 2%
AC MPS Signature	Vport = 12VDC - 60VDC, Port Connected	AC Impedance	24KΩ (0.1μF + 330Ω)
		Resistance Accuracy $\Delta V / \Delta I$ at 2 Volt Spacings	22.8KΩ, ± 250Ω
	Port Isolated	AC Impedance (≤ 500 Hz)	≥ 1.1 MΩ
		AC Impedance (≤ 120 Hz)	≥ 3.0 MΩ

Current Load Specifications			
Description	Conditions	Parameter	Specification
Load Current	Per Powered Pair	Range	0 to 750 mA
		Resolution	0.25 mA
		Accuracy	± 0.5% ± 0.25mA
		Slew Rates	> 4mA / μsec
		Activation Voltage	15V, Rising Vport
		De-Activation Voltage	14V, Falling Vport

Current Load Specifications			
Transition Current	Load Current Active, Per Powered Pair	Range	0 to 400 mA
		Resolution	0.25 mA
		Accuracy	$\pm 0.5\% \pm 0.25\text{mA}$
		Slew Rates	$> 4\text{mA} / \mu\text{sec}$
		Activation Voltage	14V, Falling Vport
		De-Activation Voltage	6V, Falling Vport
Configurable Load Transient	Vport > 15VDC	Load Step 1 Range	0 to 2000 mA
		Load Step 2 Range	0 to 750 mA
		Resolution (0 – 1023 mA)	0.25 mA
		Resolution > 1023 mA	0.50 mA
		Accuracy	$\pm 1\% \pm 0.5\text{mA}$
		Slew Rates	$> 4\text{mA} / \mu\text{sec}$
		Steps	2
		Load Step 1 Duration < 1024 mA	200 μsec to 1 sec
		Load Step 1 Duration > 1023 mA	200 μsec to 80 msec
		Load Step 2 Duration	20 μsec to 1 sec (or persist)
		Step Resolution	100 μs
		Saturated Load Eff. Resistance	37 Ω
		Foldback Suppression Minimum Port Voltage (@ 400mA PSE Current Limiting)	33 VDC
Foldback Suppression Duration	Step 1 + Step 2 Duration		

DC Metering Specifications			
Description	Conditions	Parameter	Specification
Voltage Meter	Average, Max-Peak, Min-Peak, Scope Trace	Voltage Range	0 - 60V
		Trace Length	256 Samples
		Sample Rates	39.1 μsec – 39.1 msec (10msec -- 10sec traces)
		Resolution	0.025 V
		Accuracy ¹	$\geq 30\text{VDC}$: $\pm 1.5\% + 15.6\text{ mV}$ $< 30\text{VDC}$: $\pm 2.0\% + 15.6\text{ mV}$
		Measurement Triggers	Immediate, Edge, Event
Current Meter	Average, Max-Peak, Min-Peak, Scope Trace	Current Range	0 – 2000 mA
		Trace Length	256 Samples
		Sample Rates	39.1 μsec – 39.1 msec (10 msec -- 10sec traces)
		Resolution (0 – 1023 mA)	0.25mA
		Resolution (1024 – 2000 mA)	0.5mA
		Accuracy ²	$\pm 0.5\% \pm 0.5\text{mA}$
		Triggers	Immediate, Edge, Event

1. Does not include Voltage drop due to cable losses and 0.45 Ω maximum test port input resistance.

2. Does not include Port-Connected MPS current, which is approximately (Vport - 12V)/24k Ω .

AC Metering Specifications			
Description	Conditions	Parameter	Specification
AC Peak-Peak Meter	Low Band	3dB Bandwidth	16Hz – 500Hz
	High Band	3dB Bandwidth	1500Hz – 300kHz
	Full Band	3dB Bandwidth	16Hz – 300kHz
	All Bands	Resolution	1mV
		Accuracy	2% $\pm 8\text{mV}$
		Range	1Vp-p

Triggering Specifications			
Description	Conditions	Parameter	Specification
Edge & Event Triggers	All Modes	Range	0.25V - 59.5V
		Resolution	0.125 mV
		Accuracy (relative to DC Meter)	+ 0.0625 mV
		Trig1 to Meter or Transient Latency	~ 50 μ secs
		Event Trigger Latency	< 500 μ secs
	Trigger Noise Immunity	Pre-Trigger Qualification Time (Voltage below Rising threshold or above Falling threshold)	1.5 msec
		Normal Mode Edge Noise Rejection	125 mV
	Noisy Mode Edge Noise Rejection	500 mV	

Time Interval Metering Specifications			
Description	Conditions	Parameter	Specification
Time Interval Meter	Microsecond scale	Time Range	4 – 26200 μ s
		Time Resolution	1 μ sec
		Time Accuracy	+ 2 μ secs
		Min. Resolvable Time Interval	~ 4 μ secs
	Millisecond scale	Time Range	2-6550 ms
		Time Resolution	0.1 msec
		Time Accuracy	+ 1 msec
		Min. Resolvable Time Interval	2 msec
	Second Scale	Time Range	0.1 – 16.1 sec
		Time Resolution	0.1 sec
		Time Accuracy	+ 0.05 sec
		Min. Resolvable Time Interval	0.1 sec
	Triggering & Noise Immunity	Start Trigger	Edge or Event
		Stop Trigger	Edge
		Normal Mode Edge Noise Rejection	125 mV
		Noisy Mode Edge Noise Rejection	500 mV

LED Indicators		
LED Label	Parameter	Description
DET	Detection Enabled	ON: Valid Detection Signature Connected (R= 19 to 26 K Ω , C= 0 μ F) AND Port Switch Connected BLINKING: Configured for LAN Termination. Long on-time blink for LINK UP, short on-time blink for UNLINKED. OFF: Invalid or no PD Signature AND configured as through.
PWR	PSE Power On	ON: Indicates Power-Up with Vport > 36 VDC (Regardless of Trigger State) OFF: Vport < 36 VDC
ARM	Trigger ARM	ON: Trigger 1 in the ARMED State OFF: Trigger 1 NOT in the ARMED State
AUX	Communications	ON or BLINKING: Indicates Communications to PSA Test Port

Programming and Control	
Description	Specification
Interface	Ethernet 10/100BaseT
Host Requirements	PC running Microsoft Windows NT, 2000, XP, Vista, or Linux PC (Fedora, SUSE)
Control Environment	Sifos PowerShell or PSA-Interactive
Recommended Network Latency:	< 5 msec



Physical and Environmental	
Description	Specification
Dimensions	4"W x 1. 5"H x 8.5"D
Weight	1.2 lbs
Power	100VAC-240VAC, 50-60 Hz, 5VDC, 700mA (External Power Module Included)
Ambient Operating Temperature	0°C to 50°C (≤ 42.75 Watt loading per port)
Storage Temperature	-20°C to 85°C
Operating Humidity	5% to 95% RH, Non-Condensing.

Certifications	
Description	Certifications
Emissions	FCC Part 15, Class A Meets EN55022 VCCI, AS/NZS 3548
Safety	CSA Listed (CSA22.2 No. 61010) Meets EN61010-1 CB Scheme IEC 61010-1
European Commission	Low Voltage Directive (73/23/EEC) Electromagnetic Compatibility Directive (89/336/EEC) CE Marking Directive (93/68/EEC)
<p>FCC Statement:</p> <p>This equipment has been tested and found to comply with the limits for a Class A digital device, pursuant to part 15 of the FCC Rules. These limits are designed to provide reasonable protection against harmful interference when the equipment is operated in a commercial environment. This equipment generates, uses, and can radiate radio frequency energy and, if not installed and used in accordance with the instructions, may cause harmful interference to radio communications. Operation of this equipment in a residential area is likely to cause harmful interference in which case the user will be required to correct the interference at their own expense.</p>	

Ordering Information

PSA-3002, PowerSync Analyzer 3002 including PowerShell PSA and PSA Interactive Software

PSA-CT, PSE Conformance Test Suite for One PSA Controller (Up to 24 Test Ports)

PSA-TS1, PSE Automated Test Suite Tracking Service for One Year for One PSA Controller

PSA-TS2, PSE Automated Test Suite Tracking Service for Two Years for One PSA Controller

PSA-100-CREDIT, Trade-Up Credit for PSA-100 to New PSA-3002

PSA-LLPD, LLDP Emulation and Analysis Feature for PSA-3002

- Accessories Included:**
- Installation Guide & Configuration Chart
 - PowerSync Analyzer Reference Manual (Binder and CD)
 - Power Cord
 - Cross-Over Ethernet Cable
 - RS-232 Cable

Sifos Technologies, Inc.
1061 East Street
Tewksbury, MA 01876
+1 (978) 640-4900
www.sifos.com
sales@sifos.com

real Power from Sifos